

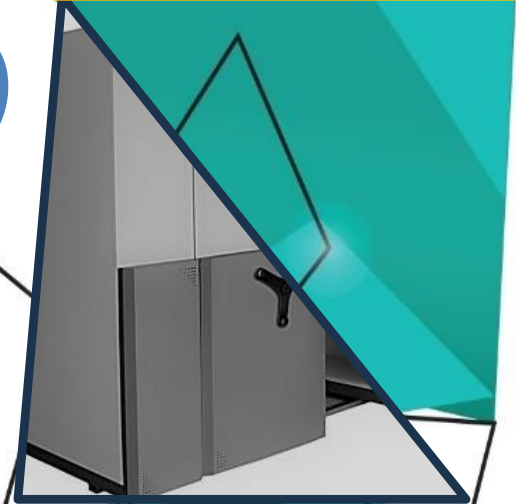

TOP NOTCH

Your Dreams ... Your Furnitures

ONE-STOP SOLUTIONS 2023

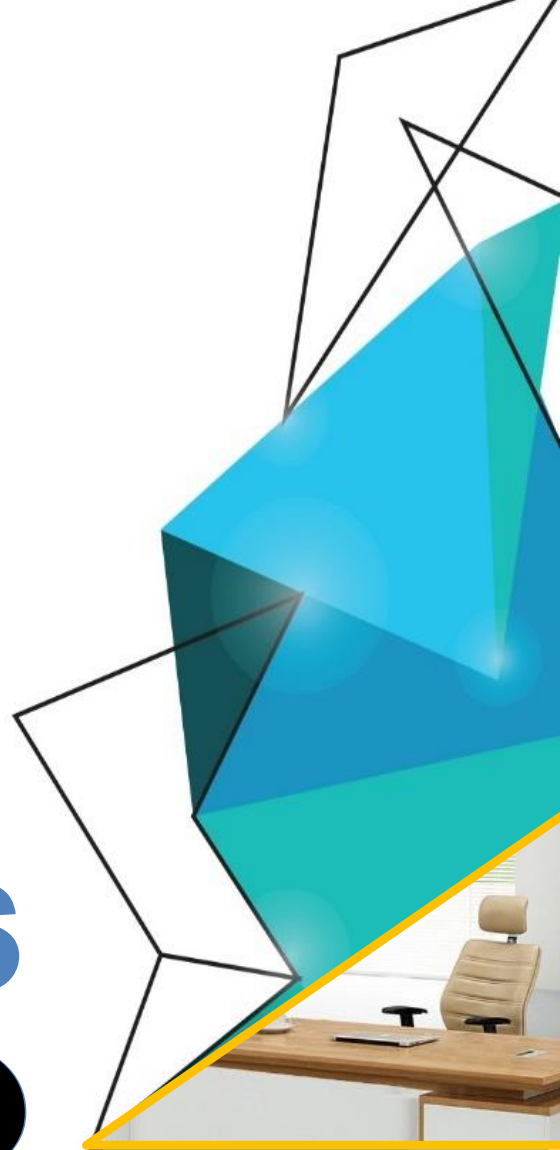



Topnotch Corporation

We are pleased to introduce ourselves as one of the fastest growing modular furniture manufacturer ,based in Jaipur, Rajasthan- India.

We are in the business of delivering value added ,interior and architectural modular furniture the wide profile of corporate commercial. Educational institution ,cafeterias , showroom ,hotels ,guest house and residential project Topnotch Corporation has earned a well- deserved reputation for its record in implementing and competing top quality project in time and with customer satisfaction.

We are associated with leading Architects ,Project Consultants ,Turnkey Contractors and developers. Our clients are large ,medium and small companies including Indian Corporate and government organizations and Individuals.

CORE VALUES :

We believes in Continuous improvement in products , technology ,material and in relations. We always Focus on priorities ,never get distracted and systematically refresh our objectives. We believe in Integrity by doing right things in reliable way. We always work to achieves Sustainable growth through waste reduction ,energy efficiency , environment care and community relations.

VISION :

"To be the top leading company by providing innovative and dynamic home and office furniture solutions in india "

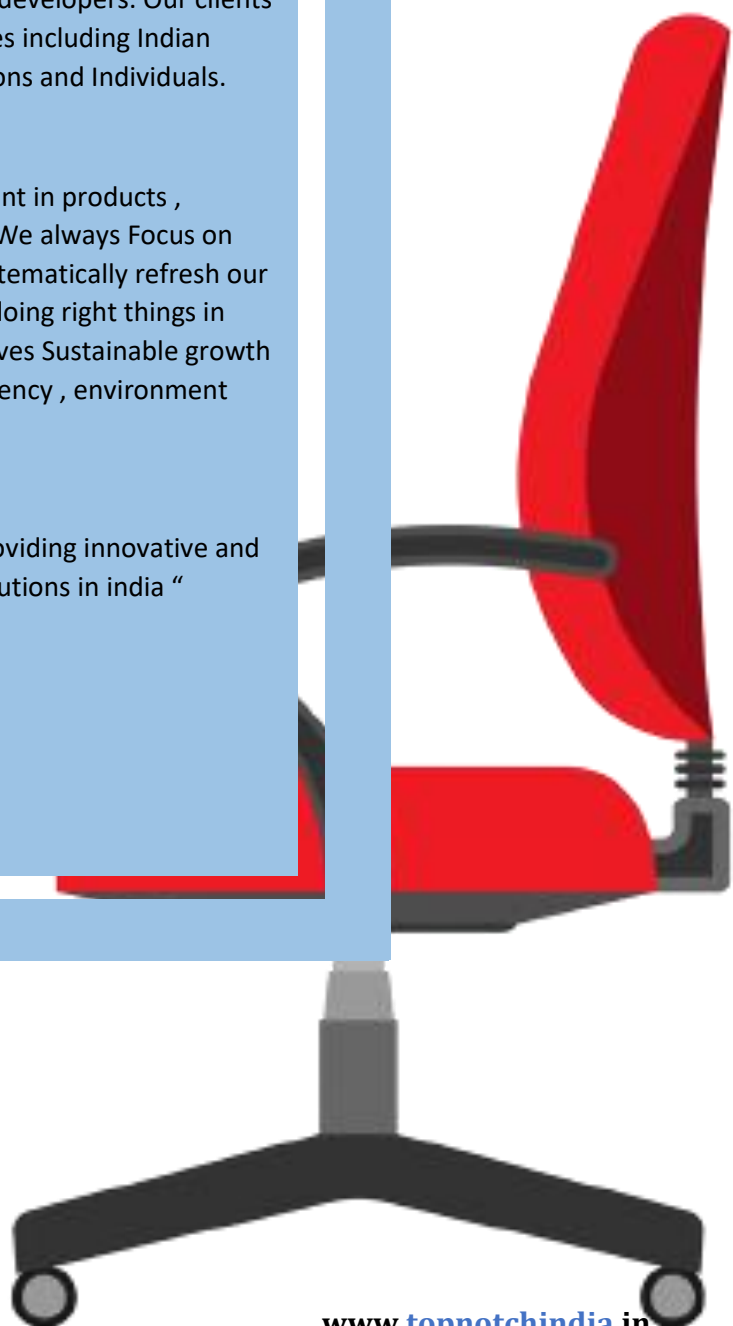

OUR VALUES

The company upholds the following values as a guideline to its operation and business transactions:

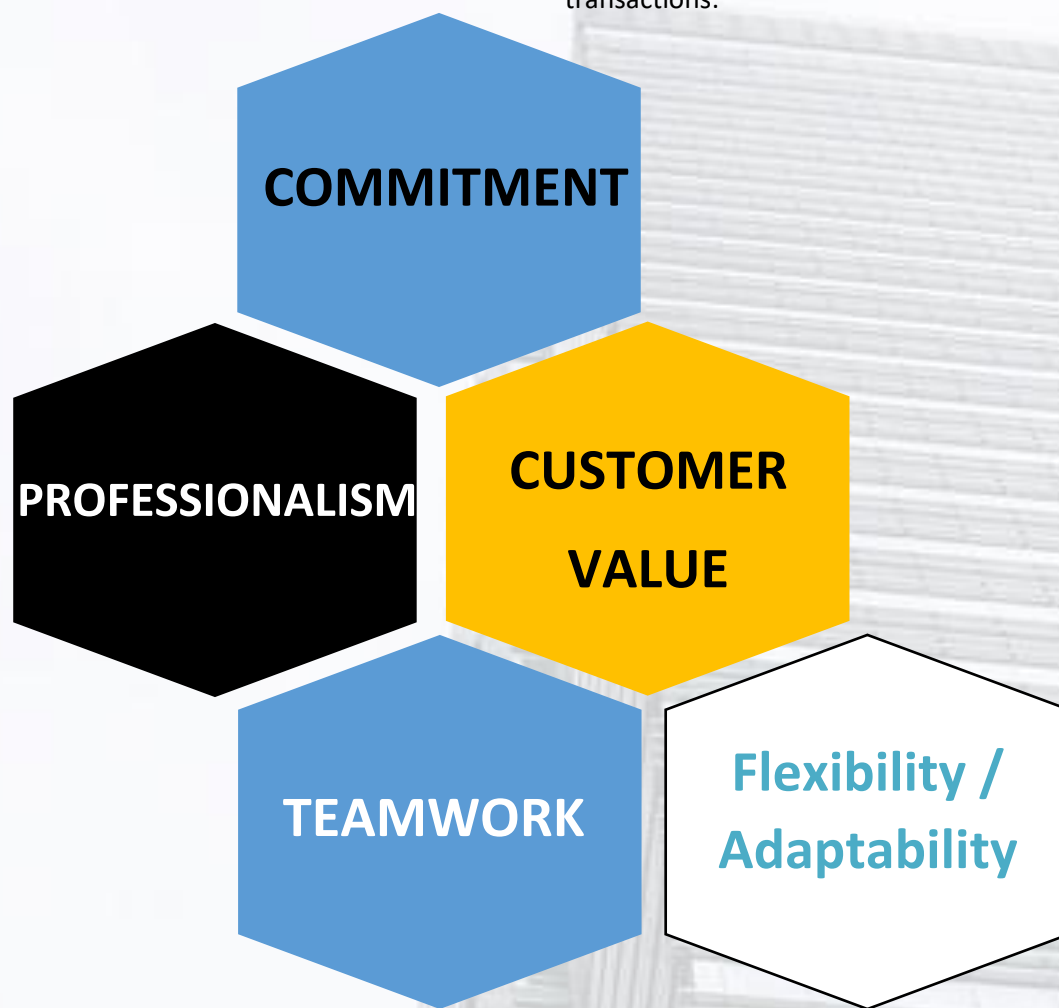

OUR MERITS

- Unique and creative solutions that meet the clients' expectations not only by realizing the clients' business objectives, but particularly by our strict adherence to the ethical principles of public relations
- Continuous search for opportunities beyond the agreed communications and business objectives
- Creative approaches to the clients' special needs in order to find unique and tailored communications solutions
- Teamwork based on the implementation of progressive communications disciplines
- Professional quality of services provided by a highly motivated team
- Courage and readiness to communicate on behalf of client in crisis
- Strong technological background
- 24/7 availability

COMPANY THAT YOU CAN TRUST



GeM
Government
e Marketplace

Office

Seating



A refined selection of our executive products providing the look and feel of quality at a competitive price.

ARENA SERIES



| ARENA 01



| ARENA 02



| ARENA 03

MILAN SERIES



| MILAN 01



| MILAN 02

| MILAN 03

MARLOS SERIES



| MARLOS 01



| MARLOS 02



| MARLOS 03

CENTURY21

TOP NOTCH

Your Dreams.. Your Furnitures..

NEW ARRIVAL



| CENTURY21 - MB

| CENTURY21 - HB



| CH901 - HB



| CH901 - MB



| CH901 - VI



| TORM - HB



| TORM - MB



| TORM - VI

Our innovative chairs and seatings are elaborately designed and crafted, and are suitable for reception areas, public areas and office space.

Mesh Chair Series HOD

KOMFY SERIES



| KOMFY HB



| KOMFY MB

SNUG SERIES



| SNUG HB



| SNUG MB



| SNUG VI

ALLURING



| ALLURING HB



| ALLURING MB



| ALLURING HB2



| ALLURING MB2

STAFF REVOLVING



| PT-R



| QT-R



| RT-R

STAFF VISITOR



| PT-VI



| QT-VI



| RT-VI

TEAM HEAD



| PT-HB



| QT-HB



| RT-HB

TREMEND



TREMEND HB



TREMEND MB

NEW ARRIVAL

- GLASS-FILLED NYLON STRUCTURED WIRE MESH ON SEAT BACK
- THE LUMBAR SUPPORT ON THE SEAT BACK
- HEIGHT ADJUSTABLE AND SLIDING ARMREST WITH SOFT TOP PU PADS
- SYNCHRO-TILT MECHANISM WITH THE MULTI-LOCKING
- MULTI-LOCK TILT MECHNISM SEATBACK WITH SEAT SLIDER
- DIE-CAST ALUMINIUM BASE WITH SMOOTH-ROLLING 5 STAR NYLON BASE CASTERS

HEADREST BOSS



| T20-HB



| T21-HB



| T22-HB



| T23-HB

HEADREST HOD



| T24-HB



| T25-HB



| T26-HB



| T27-HB

| T28-HB



| T29-HB



T SERIES



| T-HB



| T-MB



| T-VI



| N-HB



| N-MB



| N-VI1



| N-VI2

N SERIES

C SERIES



| C-HB



| C-MB



| C-MB2



| C-VI



| CORP-HB



| CORP-MB



| CORP-VI

CORP SERIES

VISTA SERIES



| VISTA-HB



| VISTA-MB



| VISTA-R1



| VISTA-R2

ROME SERIES



| ROME-HB



| ROME-MB



| ROME-VI

FONZ SERIES



| FONZ-HB



| FONZ-MB



| FONZ-VI

CARBON SERIES



| CARBON-HB



| CARBON-MB



| CARBON-LB



| CARBON-VI

MANAGERS



MGR-01



MGR-02



MGR-03



MGR-04

MANAGERS



MGR-05



MGR-06



MGR-07



MGR-08

TRAINING CHAIR



TRAN-01



TRAN-02



TRAN-03



TRAN-04



TRAN-05



TRAN-06



TRAN-07



TRAN-08



| CWS-01



| CWS-02



| CWS-03



| CWS-04



| CWS-05



| CWS-06



| CWS-07



| CWS-08



| CWS-09



| CWS-10



| CWS-11



| CWS-12



| CWS-13



| COM-01



| COM-02



| COM-03



| COM-04



| COM-05

Fabric Color Options Available for Chair Back / Chair Seat



Black

Grey

Blue

Red

Yellow

Green

Orange



Lounge chair | Longe 01



Longe 02



Longe 03



Lounge chair | Longe 04



Longe 05



Longe 06



Pentry chair | P-01



P-02



P-03



P-04



Waiting 3 Seaters | W3S-01



W3S-02



W3S-03



| TNC CF-101



| TNC CF-102



| TNC CF-103



| TNC CF-104

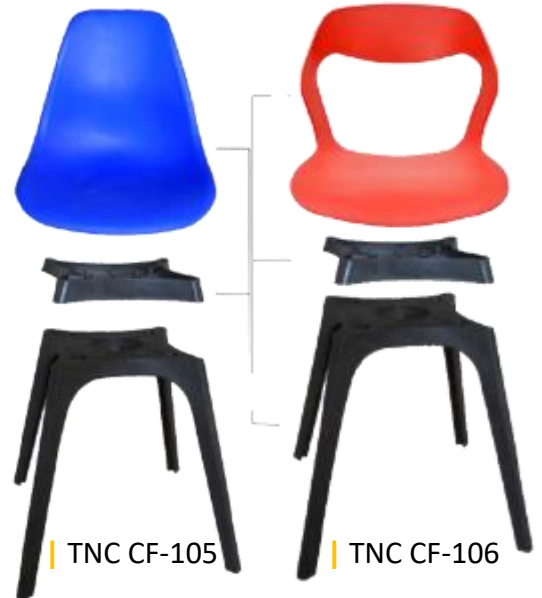

| TNC CF-105

| TNC CF-106



HIPER SERIES 101

TNC 102

TNC 103



TNC 104



TNC 105

TNC 106



TNC 107



TNC 108



TNC 109





| TNC SOFA-111



| TNC SOFA-112



| TNC SOFA-113



| TNC SOFA-114



| TNC SOFA-115



| TNC SOFA-116



| TNC SOFA-117



| TNC SOFA-118



CT 121



CT 122



CT 123



| Rostrum - 01



| Rostrum - 02



| Rostrum - 03



| Rostrum - 04



| Commute - 10



| Commute - 11



| Commute - 12



| Commute - 13



| Commute - 14



| EFHF-205



| EFHF-206



| EFHF-207



| EFHF-208



| EFHF-209



CONFERENCE TABLES



PASSIVE - 01



PASSIVE - 02



PASSIVE - 03



PASSIVE - 04



PASSIVE - 05



PASSIVE - 06



PASSIVE - 07



Rapture - 01



Rapture - 02



Rapture - 03



Rapture - 04



Rapture - 05



Rapture - 06



Rapture - 07



Rapture - 08



Zeal - 01



Zeal - 02



Zeal - 03



Zeal - 04



Zeal - 05



Zeal - 06



Zeal - 07



Eclipse - 01



Eclipse - 02



Eclipse - 03



Eclipse - 04



Eclipse - 05



Eclipse - 06



Eclipse - 07



Eclipse - 08



Eclipse - 09



Eclipse - 10



Eclipse - 11



Eclipse - 12



Eclipse - 13

Office

Desking



In this new era, an office that can be transformed freely for growth and that supports horizontal communication is necessary. Topnotch desking series designed to provide ergonomic design, convenient systems and unrestricted layout, representing a new office that **increase work efficiency**.



MONARC SERIES

MONARC MAIN TABLE :

- | 2100(W) x 900(D1) x 1200(D2) 750 MM(H) WITH ERU
- | 2400(W) x 900(D1) x 1200(D2) 750 MM(H) WITH ERU



| TABLE WITH FIXED PEDESTAL (RIGHT) | TABLE WITH FIXED PEDESTAL (LEFT)

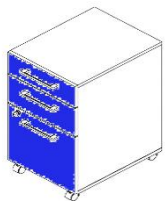

| MOBILE PEDESTAL

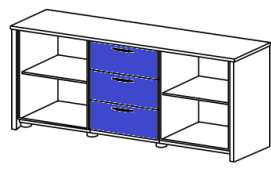

| SIDE CABINET

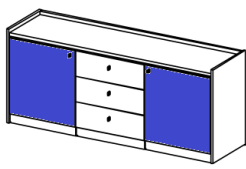

| CREDENZA



| HIGH CABINET WITH MIDDLE GLASS

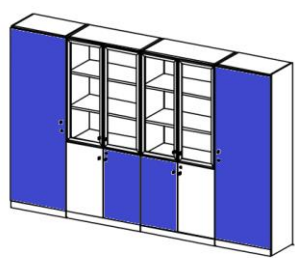

| HIGH CABINET WITH MIDDLE GLASS FULL WIDTH

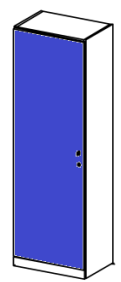

| HIGH SINGLE DOOR CABINET

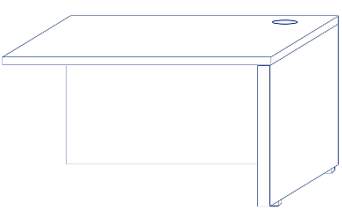
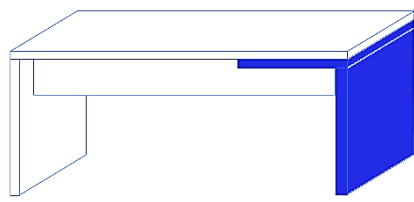



NEO SERIES



NEO 101 | MAIN TABLE

2100 X 1050 X 750MM



NEO 102 | SIDE RETURN

2100 X 1050 X 750MM



NEO 103 | COFFEE TABLE

600 X 600 X 450MM



NEO 104 | ROUND TABLE

DI.1200 X 750MM



NEO 105 | CONFERENCE TABLE

1800 X 900 X 750MM | 2400 X 900 X 750MM



NEO 106 | SIDE RETURN PEDESTAL CABINET

400 X 380 X 450MM



NEO 107 | SIDE CABINET

1200 X 450 X 750MM



NEO 108 | MID CABINET

800 X 450 X 1200MM



NEO 109 | HIGH CABINET

800 X 450 X 2000MM



NEO 110 | HIGH

800 X 450 X 2000MM



LEGENDER SERIES

LEGENDER MAIN TABLE :

- | 2100(W) x 900(D1) x 1200(D2) 750 MM(H) With ERU
- | 2400(W) x 900(D1) x 1200(D2) 750 MM(H) With ERU

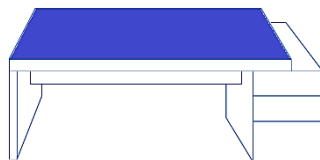

| TABLE WITH FIXED PEDESTAL (RIGHT)

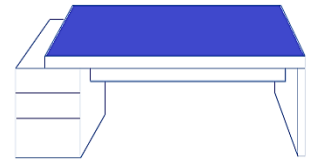

| TABLE WITH FIXED PEDESTAL (LEFT)

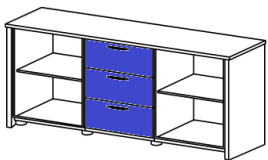

| SIDE CABINET

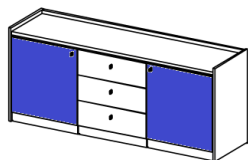

| CREDEZZA

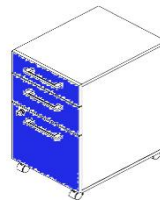

| MOBILE PEDESTAL



| SIDE CONNECTING TYPE
1200 X 450 X 750MM

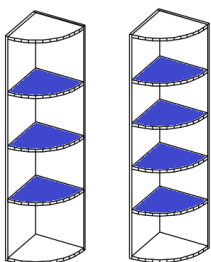

| CORNER CABINET

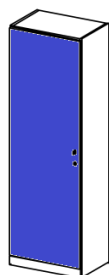

| HIGH SINGLE DOOR CABINET

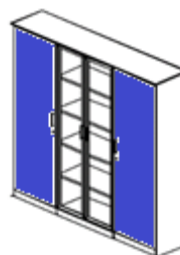

| HIGH CABINET WITH MIDDLE CLASS

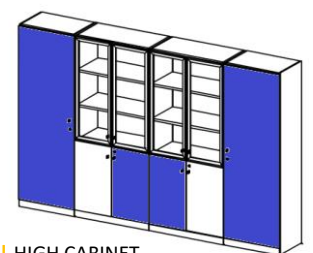

| HIGH CABINET WITH MIDDLE GLASS AND FILLER



CONTESSA SERIES

CONTESSA MAIN TABLE :

- | 2100(W) x 900(D1) x 1200(D2) 750 MM(H) With ERU
- | 2400(W) x 900(D1) x 1200(D2) 750 MM(H) With ERU

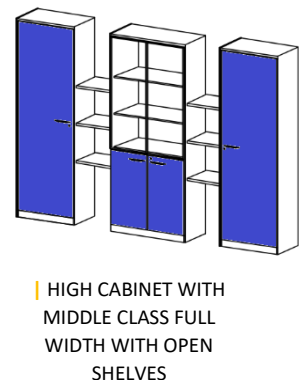
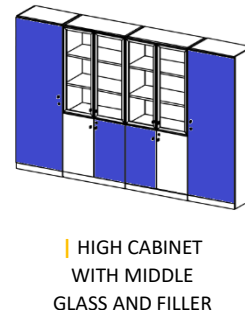
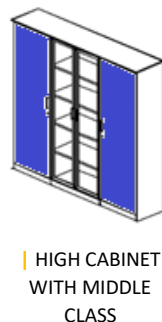
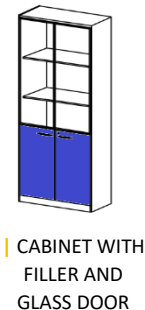
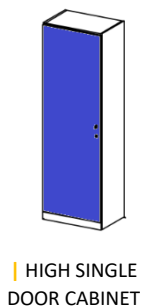
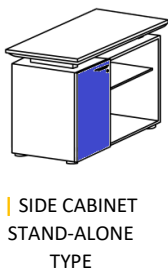
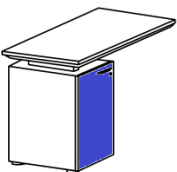
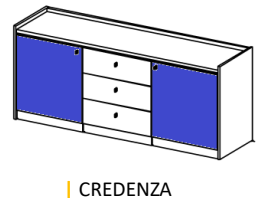
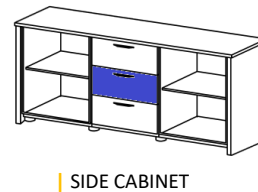
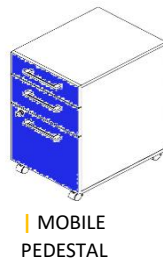
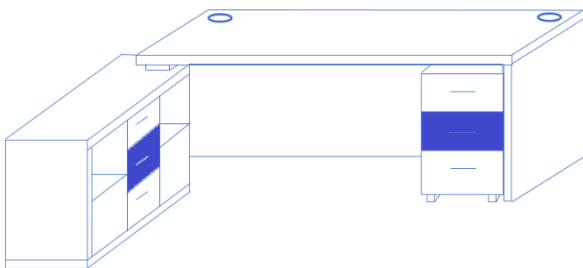
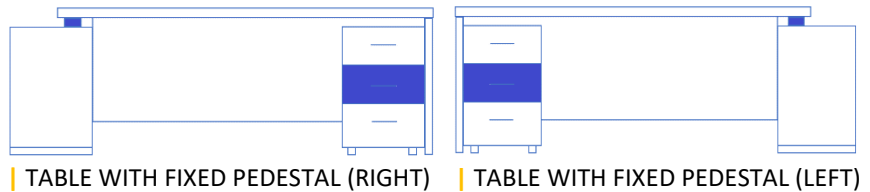



PEXTONA SERIES

PEXTONA MAIN TABLE :

- | 2100(W) x 900(D1) x 1200(D2) 750 MM(H) With ERU
- | 2400(W) x 900(D1) x 1200(D2) 750 MM(H) With ERU



| PEXTONA T 102



| PEXTONA T 103



| SIDE CABINET



| MOBILE PEDESTAL



| HIGH CABINET WITH GLASS AND FILLER



| MIDDLE CABINET

| HIGH CABINET WITH MIDDLE GLASS, OPEN BOOKCASE AND FILLER



| MIDDLE HEIGHT CABINET WITH OPEN BOOKCASE AND FILLER



BAROTIM SERIES

BAROTIM MAIN TABLE :

- | 2100(W) x 900(D1) x 1200(D2) 750 MM(H) With ERU
- | 2400(W) x 900(D1) x 1200(D2) 750 MM(H) With ERU



| BAROTIM T 102



| BAROTIM T 103



| SIDE CONNECTING TYPE



| HIGH OPEN CABINET



| HIGH CABINET WITH GLASS AND FILLER



| SIDE OPEN CABINET



| SIDE CABINET



| MOBILE PEDESTAL

ALWINO SERIES



ALWINO MAIN TABLE :
| 2100(W) x 900(D1) x 1200(D2) 750 MM(H) With ERU
| 2400(W) x 900(D1) x 1200(D2) 750 MM(H) With ERU



| ALWINO T 102 WITH
FIXED PEDESTAL



| ALWINO T 103



| HIGH CABINET



| HIGH CABINET WITH
GLASS AND FILLER



| SIDE CABINET



| SIDE CABINET



| MOBILE
PEDESTAL

| FIXED PEDESTAL FOR
SIDE CONNECTING TYPE



SIGMA SERIES



Side Unit Cabinet

T-1



Side Unit Cabinet

T-2



Sigma Main Table

T-3

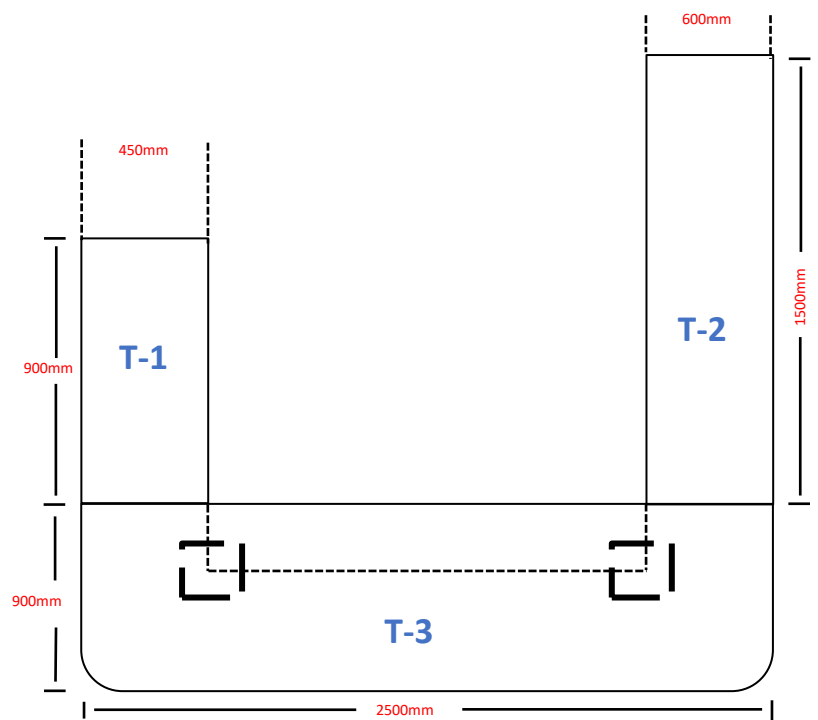

- **MAIN TABLE (T-3) SIZE:** W-2500mm X D-900mm X H-750mm
- **SIDE UNIT CABINET (T-2) SIZE:** 1500mm X 600mm X 750mm
- **SIDE UNIT CABINET (T-1) SIZE:** 900mm X 450mm X 600mm
- **Table Top Thickness:** 50mm
- **Side unit and Other Materials:** 18mm



43mm 3 Layered Prelaminated Board
with More than 20 Color Options

3 Drawers Mobile Pedestal With Castor



Side Unit Cabinet with Customization

| VIRAT 010



Primium Hardware Accessories

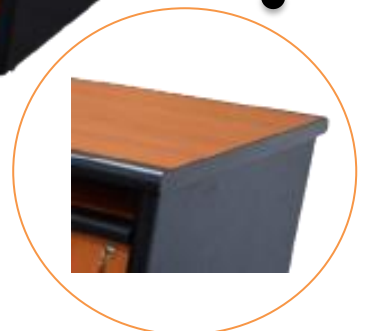

Post Form Table Top with 2mm Edge Banding that gives Primium Finished



Primium Quality with Heavy Duty Telescopic Channel



| VIRAT 011



| VIRAT 012



| TNC-ET-200

PREMIUM EXECUTIVE TABLE SERIES



| TNC-ET-201



| TNC-ET-202



| TNC-ET-203



| TNC-ET-204





MODEL NO: TNC-8745

SIZE : MAIN TOP 2400MM X 900MM X 750MM
SIDE UNIT CABINET : 1200MM X 650MM X450MM
MOBILE PEDESTAL : 450MM X 400MM X650MM



MODEL NO: TNC-8746

SIZE : MAIN TOP 2400MM X 900MM X 750MM
SIDE UNIT CABINET : 1200MM X 650MM X450MM
MOBILE PEDESTAL : 450MM X 400MM X650MM



MODEL NO: TNC-8747

SIZE : MAIN TOP 2400MM X 900MM X 750MM
SIDE UNIT CABINET : 1200MM X 650MM X450MM
MOBILE PEDESTAL : 450MM X 400MM X650MM

OFHOD 01



OFHOD 02



OFHOD 03



OFHOD 04



OFHOD 05



OFHOD 06

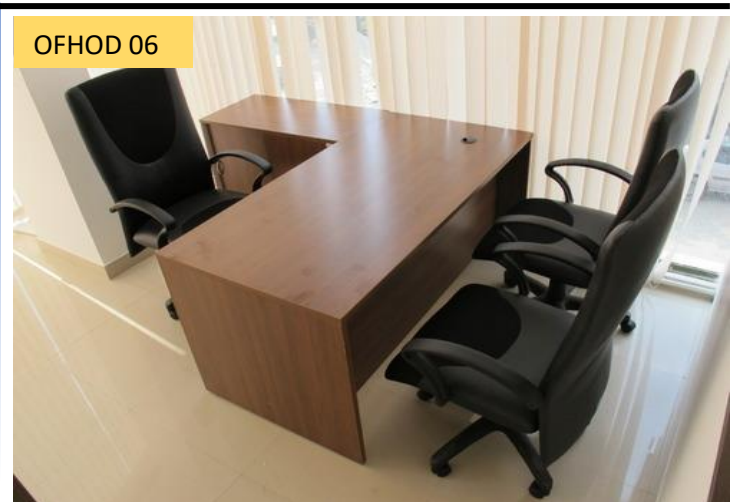

Table with Side Unit :

- 1500 X 750 X 750MM
- 1500 X 900 X 750MM
- 1800 X 750 X 750MM
- 1800 X 900 X 750MM

Side unit :

- 1050 X 457 X 750MM
- 1200 X 457 X 750MM

Pedestal :

- 400 X 450 X 680MM

L Shaped Table :

- 1500 X 750 X 1050 X 750MM
- 1500 X 900 X 1200 X 750MM
- 1800 X 750 X 1050 X 750MM
- 1800 X 900 X 1200 X 750MM

Back unit :

- 1500 X 457 X 750MM
- 1800 X 457 X 750MM

Pedestal :

- 400 X 450 X 680MM



OFST 01



OFST 02



OFST 03



OFST 04



OFST 05



OFST 06



OFST 07



OFST 08



| TNC-OT-212



| TNC-OT-213



| TNC-OT-214



| TNC-OT-215

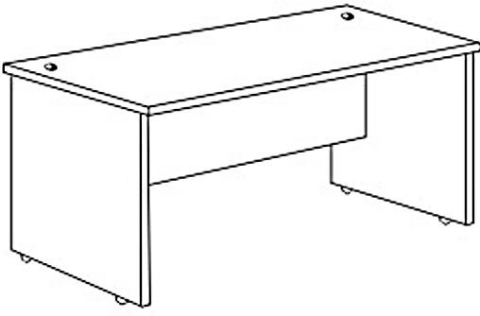

TABLE

- 1200 X 600 X 750 MM
- 1500 X 900 X 750 MM
- 1800 X 900 X 750 MM
- 1800 X 1200 X 750 MM
- 2100 X 900 X 750 MM
- 2100 X 1200 X 750 MM

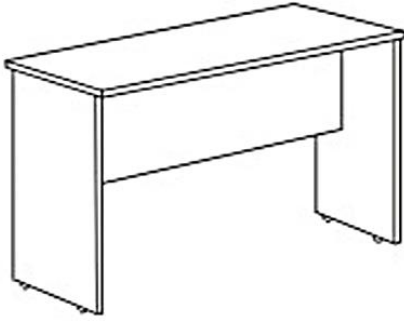

SIDE TABLE

- 900 X 450 X 700 MM
- 1200 X 450 X 700 MM
- 1500 X 450 X 700 MM

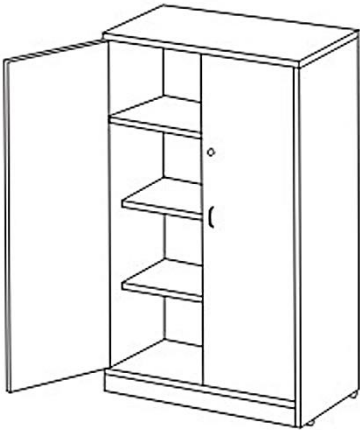

HIGH CABINET

- 800 X 450 X 1700 MM
- 800 X 450 X 1700 MM (GLASS DOOR)

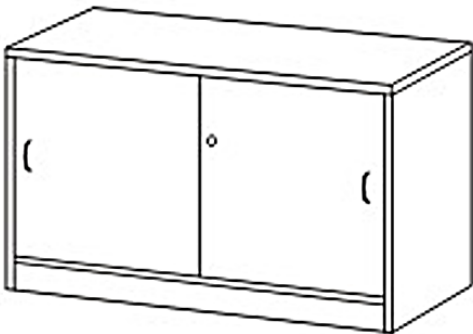

SIDE CABINET

- 1050 X 450 X 750 MM
- 1200 X 450 X 750 MM



MOBILE PEDESTAL

- 400 X 480 X 680 MM
- 400 X 480 X 725 MM
- 450 X 500 X 680 MM
- 450 X 500 725 MM





Wooden Cupboard

CUPBOARD	CODE	CUPBOARD	CODE	CUPBOARD	CODE	CUPBOARD	CODE
800 X 450 X 2010 MM	OFSS201	800 X 450 X 1800 MM	OFSS203	800 X 450 X 1200 MM	OFSS205	800 X 450 X 750 MM	OFSS207
900 X 450 X 2010 MM	OFSS202	900 X 450 X 1800 MM	OFSS204	900 X 450 X 1200 MM	OFSS206	900 X 450 X 750 MM	OFSS208



Wooden Bookcase

BOOKCASE	CODE	BOOKCASE	CODE	BOOKCASE	CODE	BOOKCASE	CODE
800 X 450 X 2010 MM	OFSS209	800 X 450 X 1800 MM	OFSS211	800 X 450 X 1200 MM	OFSS213	800 X 450 X 750 MM	OFSS215
900 X 450 X 2010 MM	OFSS210	900 X 450 X 1800 MM	OFSS212	900 X 450 X 1200 MM	OFSS214	900 X 450 X 750 MM	OFSS216



Wooden Filing Cabinet

2 DRAWERS FILLING CABINET	CODE	3 DRAWERS FILLING CABINET	CODE	4 DRAWERS FILLING CABINET	CODE	DESK HIGH LATERAL FILLING CABINET	CODE
465 X 600 X 685 MM	OFSS217	465 X 600 X 1050 MM	OFSS218	465 X 600 X 1380 MM	OFSS219	800 X 600 X 750 MM	OFSS220

We offer a variety of storage solutions from side file cabinets for documents archiving to bins that will keep office in a tidy order.



MINI CONFERENCE TABLE	CODE
1800 X 1200 X 750 MM	OFDS101
2400 X 1200 X 750 MM	OFDS102



MIN CONFERENCE TABLE	CODE
1800 X 1200 X 750 MM	OFDS103
2400 X 1200 X 750 MM	OFDS104



BOARDROOM TABLE	CODE
1800 W X 1050 D X 750 H MM	OFDS105
2400 W X 1250 D X 750 H MM	OFDS106



ROUND MEETING TABLE	CODE
1200 X 750 MM (DIA X H)	OFDS107
1500 X 750 MM (DIA X H)	OFDS108



BENCH	CODE
1200 X 450 X 450 MM	OFDS109
1200 X 450 X 480 MM	OFDS110



DISPATCH TABLE	CODE
1200 X 600 X 750 MM	OFDS111
1500 X 600 X 750 MM	OFDS112



DISCUSSION TABLE	CODE
1200 X 600 X 750 MM	OFDS113
1500 X 600 X 750 MM	OFDS114



STEEL BASE TABLE	CODE
1200 W X 600 D X 750 H MM	OFDS115
1500 W X 600 D1 X 1350 D2 X 750 MM	OFDS116



Modular Table

Cum Conference Table



Realising the need for reconfigurable meeting facilities this training and conference room furniture fits the bill precisely a huge range of colours are available in MDF/PLPB top to sit on a welded underframe, with 40mm diameter tubular legs.



| Rectangular



| Semi Circular



| Trapezoidal



| Rectangular - 360°



| Semi Circular - 360°



| Trapezoidal - 360°



Conference
Connection Table
1500/1800/2400 X
1200/1500 X 750MM



Conference
Connection Table
1500/1800 X 600 X
750MM

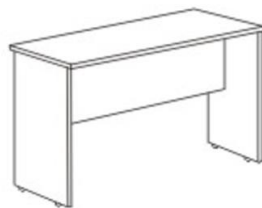

Conference
Connection Table
1200/900 X 450 X
750MM

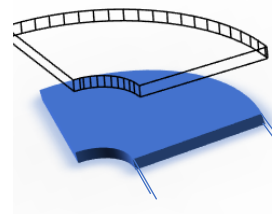

90° Connection Top
180° Connection Top
For 600 and 900mm
Depth

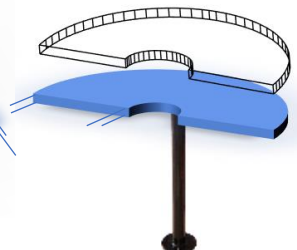

Half Round
Connection Top
with Leg

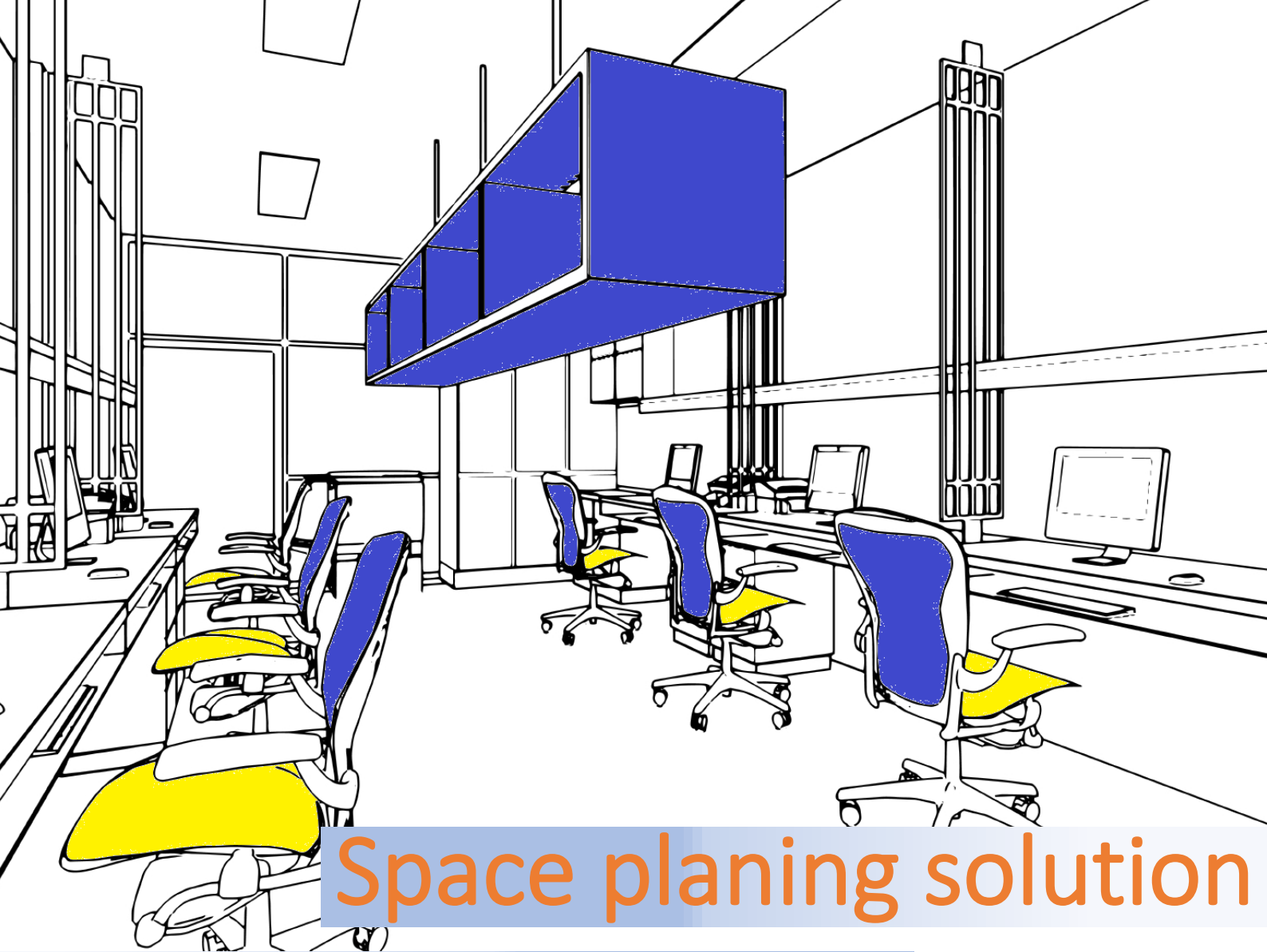

Space planing solution

Modular Workstation





Client Satisfaction Guaranteed Our customers are our top priority and we stay with you every step of the way. Even after our products have been delivered, we are always one call away to answer any follow up questions. We are committed to the needs of your organization, your budget and your time. No one in the industry protects your purchasing decision better than **Topnotch Corporation**.

HIGHLIGHTS

30mm th pole/panel based

50-54mm panel based system

60 & 75 mm tile based system

Non-Territorial workplace and Personal workstation

Double Raceways and Pop-up Box Options

Designed based on Available space @Design Studio

Fabric, White Board, Pin Board and Laminate For above table

Movable, Fixed, Joint Cabinet and Overhead Storage

**DESIGNED TO MAKE OFFICE PLANNING
ENDLESSLY CUSTOMIZABLE.**

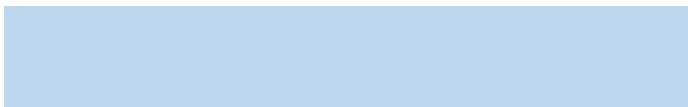

We Make Spaces More Functional And Appealing with delivering The Latest Trends, Our designer dedicated to finding elegant solutions that will look as good as you dreamed.



**DESIGNED
BY US. DREAMED
BY YOU.**



YES !

**WE KNOW
WHAT GOES
ON IN
DREAM.**



'Y' Shaped Work station :



'Curvilinear' Work station :



'Linear' Work station :



'C Shaped' Work station :



WORKSTATION DETAILS SPECIFICATION

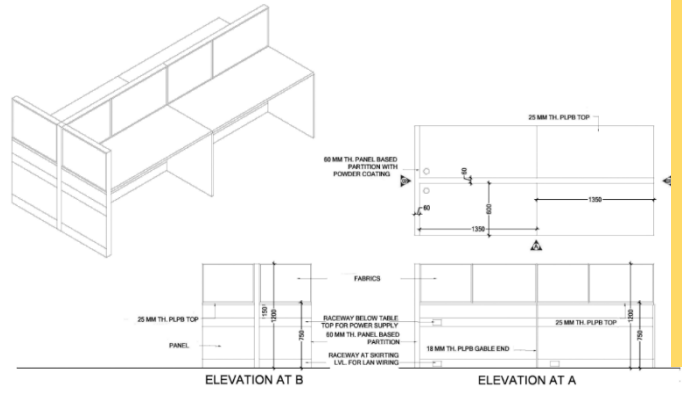
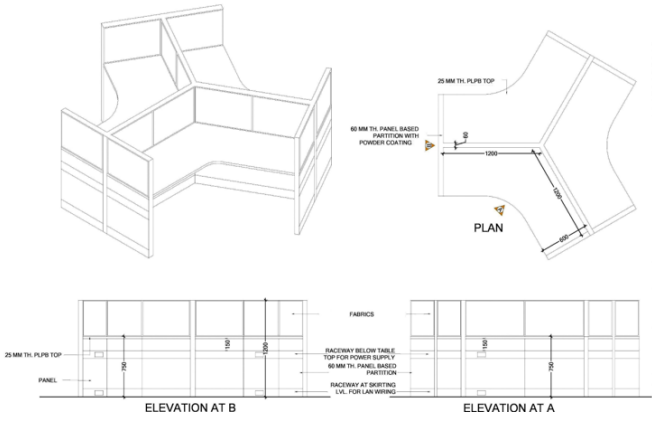

ISOMETRIC DRAWING

DETAILED CONFIGURATION

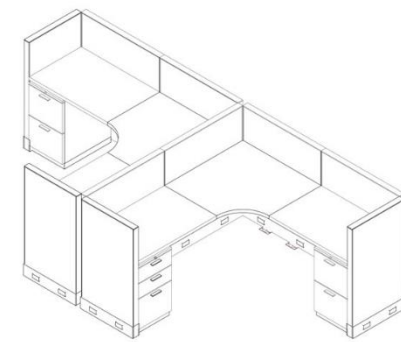
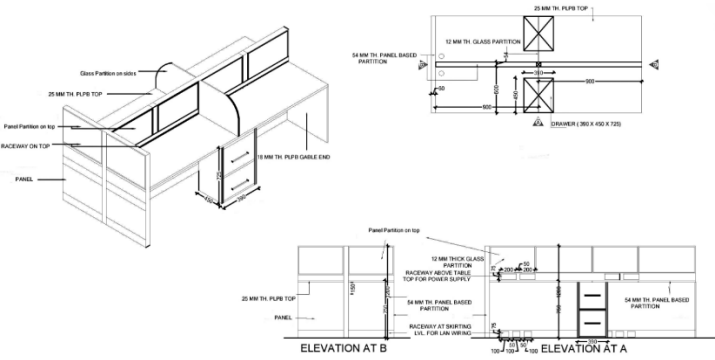

FLEXIBILITY IN DESIGN

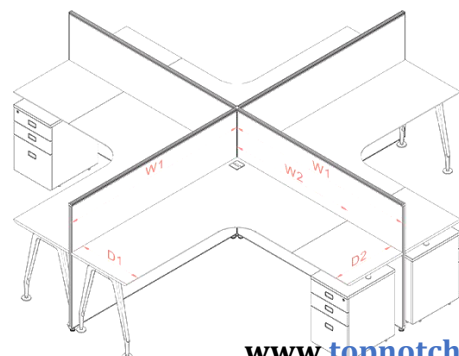

OPTION SELECTION DETAILS

START-UP SERIES



WSOT 400



WSOT 401



WSOT 402



WSOT 403



WSOT 404



WSOT 405

We are here with Solution to Provide Large numbers of design for Modular Work Station as per your needs.



Adds a Superior Look to the Interiors | Wide Variety | Flexibility | Provides Privacy | Easy to Move | Storage Spaces Included | Cost-Effective | Environment Friendly

Modular Work Station Layouts



Linear Type Staff Workstation with Panel (Non Sharing) - 1 seater



Linear Type Staff Workstation with Panel (Non Sharing) - 2 seaters



Linear Type Staff Workstation with Panel (Non Sharing) - 3 seaters

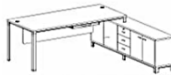

HOD Work table With Side Credenza



HOD Work table With Side Credenza - Sharing 2 Seating



HOD Work table With Pedestal



Linear Type Staff Workstation with Panel (Double Sharing) - 2 seaters



Linear Type Staff Workstation with Panel (Double Sharing) - 4 seaters



Linear Type Staff Workstation with Panel (Double Sharing) - 6 seaters



Linear Type Staff Workstation with Panel (Double Sharing) - 2 seaters



Linear Type Staff Workstation with Panel (Double Sharing) - 4 seaters



Linear Type Staff Workstation with Panel (Double Sharing) - 6 seaters



Linear Staff Workstation with Screen (Double Sharing) - 2 seaters



Linear Staff Workstation with Screen (Double Sharing) - 4 seaters



Linear Staff Workstation with Screen (Double Sharing) - 6 seaters



Linear Type Staff Workstation with Screen (Double Sharing) - 2 seaters



Linear Type Staff Workstation with Screen (Double Sharing) - 4 seaters



Linear Type Staff Workstation with Screen (Double Sharing) - 6 seaters



L-Type Cubical Workstation

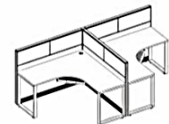

T-Type Cubical Workstation



X Type Cubical Workstation - 4 seaters



L-shape Cubical Workstation

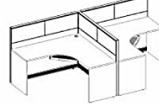

T-shape Cubical Workstation



X-shape Cubical Workstation



Linear Staff Workstation panel base 1 seater



Linear Staff Workstation panel base - 2 seater



Linear Staff Workstation panel base - 2 seater back to back



Linear Staff Workstation panel base - 4 seater



Y shaped Staff Workstation panel base - 3 seater



Y shaped Staff Workstation panel base - 6 seater



Curvilinear Staff Workstation panel base Single side- 1 seater



Curvilinear Staff Workstation panel base Single side- 2 seater



Curvilinear Staff Workstation panel base Single side- 4 seaters

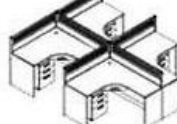

Curvilinear Staff Workstation panel base Double side- 4 seater

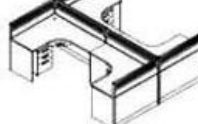

Curvilinear C Type Staff Workstation panel base Single side- 1 seater



Staff Workstation Open Type below Motesty Single side- 1 seater



Linear Type Staff Workstation with Screen (Non Sharing) - 3 seaters

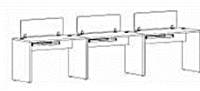

Linear Staff Workstation with Screen (Non Sharing) - 3 seaters



Linear Type Staff Workstation with Panel (Non Sharing) - 2 seaters



Linear Type Staff Workstation with Panel (Non Sharing) - 3 seaters



Linear Type Staff Workstation with Screen (Non Sharing) - 1 seater



Linear Type Staff Workstation with Screen (Non Sharing) - 2 seater

LINE UP

REGULAR SIZES

Single Side Type

WITH 45/50/60/75MM ALL SIZE IN MM

WIDTH	DEPTH	HEIGHT	CODE
900	600	750 FOR TOP 1200 FULL	WSL1001
1200			WSL1002
1500			WSL1003
1800			WSL1004
2400			WSL1005
900	750		WSL1006
1200			WSL1007
1500			WSL1008
1800			WSL1009
2400			WSL1010

Double Side Type

WITH 45/50/60/75MM ALL SIZE IN MM

WIDTH	DEPTH	HEIGHT	CODE
900	1200	750 FOR TOP 1200 FULL	WSL1011
1200			WSL1012
1500			WSL1013
1800			WSL1014
2400			WSL1015
900	1500		WSL1016
1200			WSL1017
1500			WSL1018
1800			WSL1019
2400			WSL1020

Single Side Type

WITH 45/50/60/75MM ALL SIZE IN MM

WIDTH	D1	D2	HEIGHT	CODE
1500	600	1500	750 FOR TOP 1200 FULL	WSCL1021
1800		1800		WSCL1022
2400		2400		WSCL1023
1500	750	1500		WSCL1025
1800		1800		WSCL1026
2400		2400		WSCL1027

Double Side Type

WITH 45/50/60/75MM ALL SIZE IN MM

WIDTH	D1	D2	HEIGHT	CODE
1500	600	1500	750 FOR TOP 1200 FULL	WSCL1028
1800		1800		WSCL1029
2400		2400		WSCL1030
1500	750	1500		WSCL1031
1800		1800		WSCL1032
2400		2400		WSCL1033

Single Side Type

WITH 45/50/60/75MM ALL SIZE IN MM

W1	W2	D	HEIGHT	CODE
1200	1200	600	750 FOR TOP 1200 FULL	WSYS1034
1500	1500			WSYS1035
1800	1800			WSYS1036
1200	1200	750		WSYS1037
1500	1500			WSYS1038
1800	1800			WSYS1039

Single Side Type

WITH 45/50/60/75MM ALL SIZE IN MM

WIDTH	D1	D2	HEIGHT	CODE
1500	600	1500	750 FOR TOP 1200 FULL	WSYS1040
1800		1800		WSYS1041
2400		2400		WSYS1042
1500	750	1500		WSYS1043
1800		1800		WSYS1044

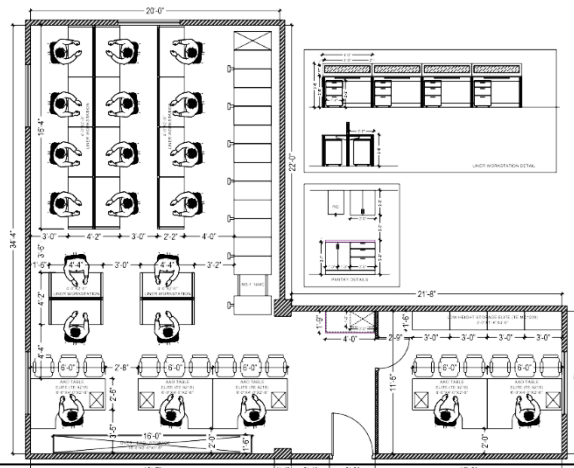
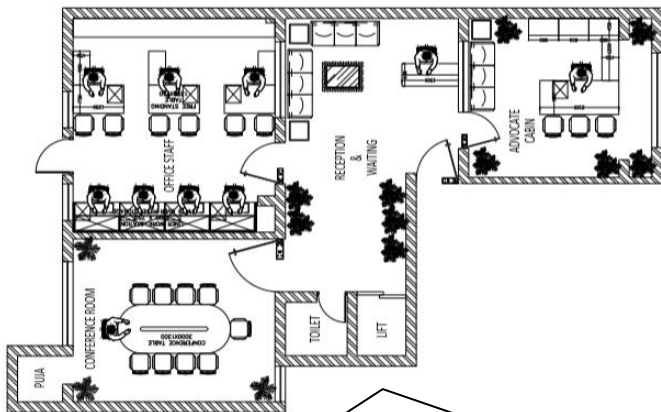

Workstation Concept is best for large numbers of employees seatings, for best seating arrangement Layout/drawing must be taken, Drawings always for spacsaver, Cluster options Selection by Size, Type, Models, Frame Type all depends on your requirement and needs. Indicated seater type, size look, arrangement & drawing seaters may be different or varies by Price and layout. Topnotch will you provide free consultancy for all type of [seating solution](#).

Workstation Cluster wise size

Fabric Colour Shades



Powder coated Colour Shades

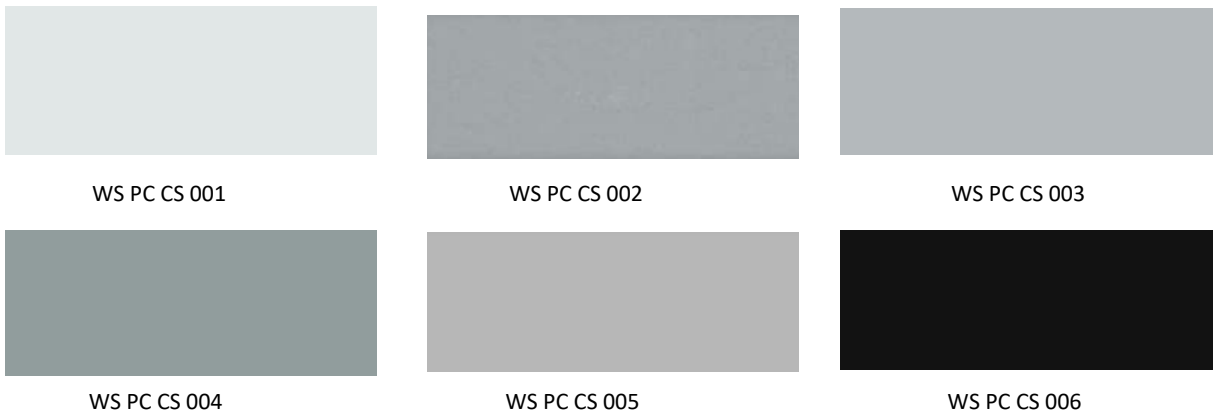

Laminate Colour Shades



SCREEN DESIGN



Fabric Cladded



Glass screen



White Board



Pre-laminated



Panel Base

ACCESSORIES



Key Board Tray



Popup Box



Wire Manager



Flip Box



CPU Trolley

FRAME DESIGN



"I" Leg frame



Loop Leg Frame



"C" Shape Leg Frame



Round tapered Leg



Panel Base

STORAGE TYPE



Mobile Pedestal Unit



Fixed Pedestal Unit



Overhead Storage Cabinet



Panel Base Overhead Storage Cabinet

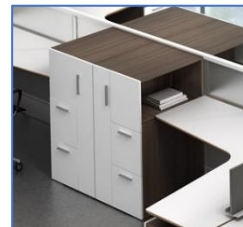

Leg Type Storage Cabinet

FLEXIBLE WORK STYLES

The Wide Range Of Accessories Allow Various Possibilities In An Office Setting. By Adding Options, It Can Even Transform A Non-Territorial Workplace To The Personal Workstation

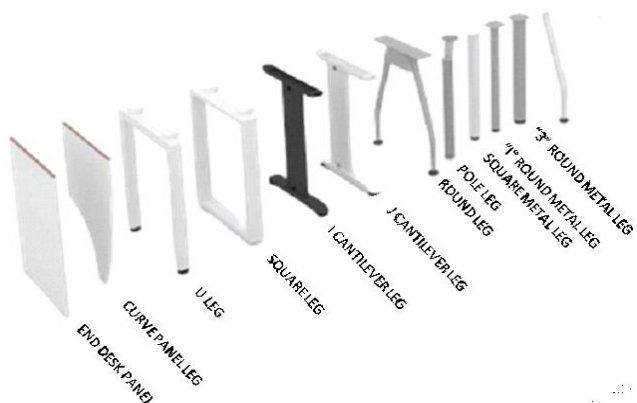

LEG TYPE



Open Leg

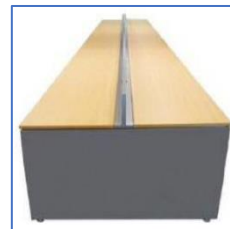

Panel leg



WORK SURFACE



Ply Board



MDF Board



Pre-Laminate Particle Board



PVC Edge Banding



Post Forming



Duck Nose

PANELS



30MM

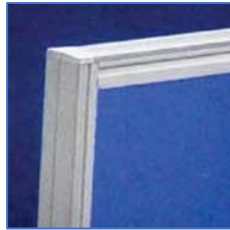

54MM



60 & 75MM



Panels

Above the table top
Below the table top



Raceways

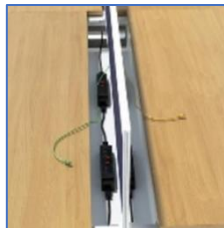

Sliding Top

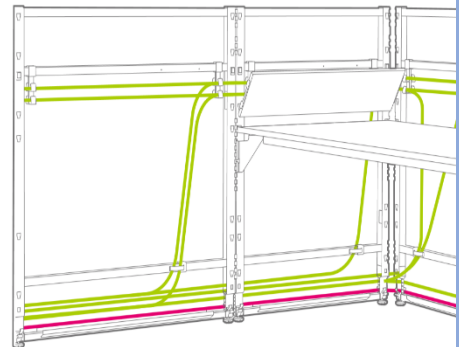

TOP PARTITION OPTION



WHITE BOARD



FABRIC

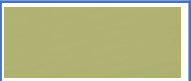

PIN BOARD

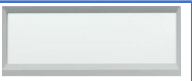

TRANSPARENT GLASS



Topnotch

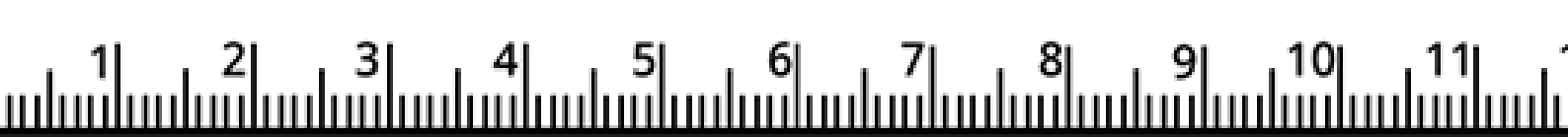

Where single "MM" gives you outcomes

Smart



Office Solutions



Solutions

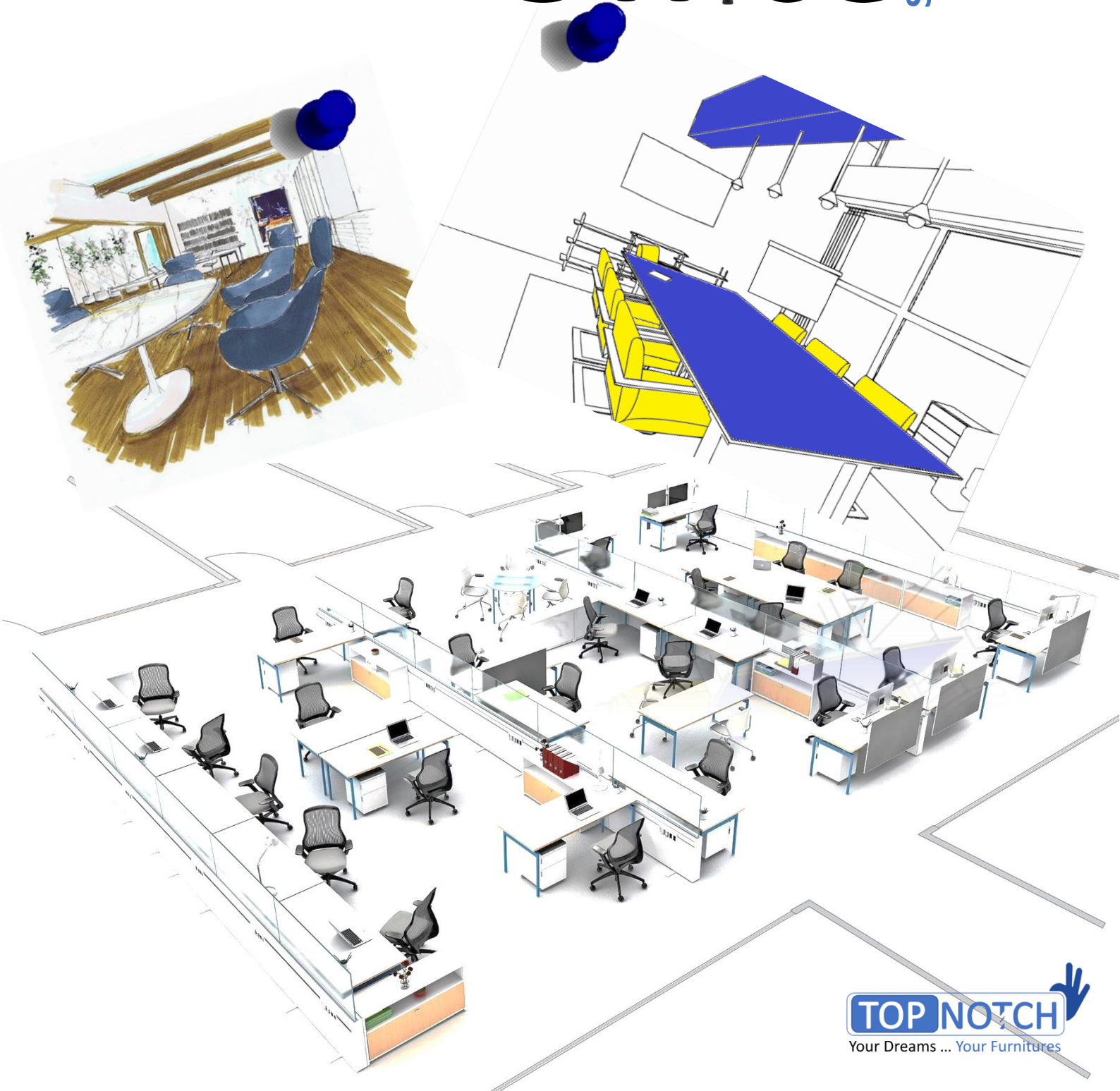

Think Smart !

We are here for making office more smart

Office Interior

FROM CONCEPT TO CREATION

We serve in Office, Retails, Hotel, Institutionals, We also Provide design solutions with right product to right Place, Topnotch is bound you to serve with best servies in Interiors execution on given time frame.



We have experienced teams with dedicated passion To give response on time to time while going project. Our solution : Designing, execution, electrical, data,voice, workstation, Conference Room, Lecture room, cabine furniture, reception , storage solution, Customized Carpentering works, physical security solution, Digital class Room,Library Furniture, Computer lab, Benches Etc



We deals from design to untill its execution We provide service in interior Execution,

- **Fall ceiling**-Wooden, gypsum, Grid Etc,
- **Wall Partition**-Glass, Wooden, Aluminum etc..
- **Flooring** – Wooden, vinyl, Carpets, Tiles, Granite, Marbles
- **Eletricals, Data,plumbing, windows, electronics, Carpentry furniture,wall papers, kitchen systems, Painting work, CCTV etc.**



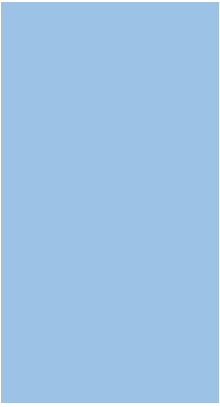

**Because Work
will be easy if
Workplace is
like our
Dreamed Place.**



Smart businesses start with Smartoffice

Our design process promotes responsible design, sustainable materials and healthy environments. We actively listen to your specific needs and through our extensive experience and market knowledge deliver innovative and unique solutions.

We provide you master plan and isometric design drawings, provisional estimate of projected cost of the work.

Proposes potential specifications and proposes a schedule for completion of the work.

OUR SERVICES

DESIGNING 2D & 3D

WALL PARTITION

FALL CEILING

FLOORING WORK

PAINTING & ...

ELECTRICAL AND DATA

CCTV & ALEXA

WINDOW BLINDS,
PANTRY, CARPENRY
WORK, LIGHTING & AC

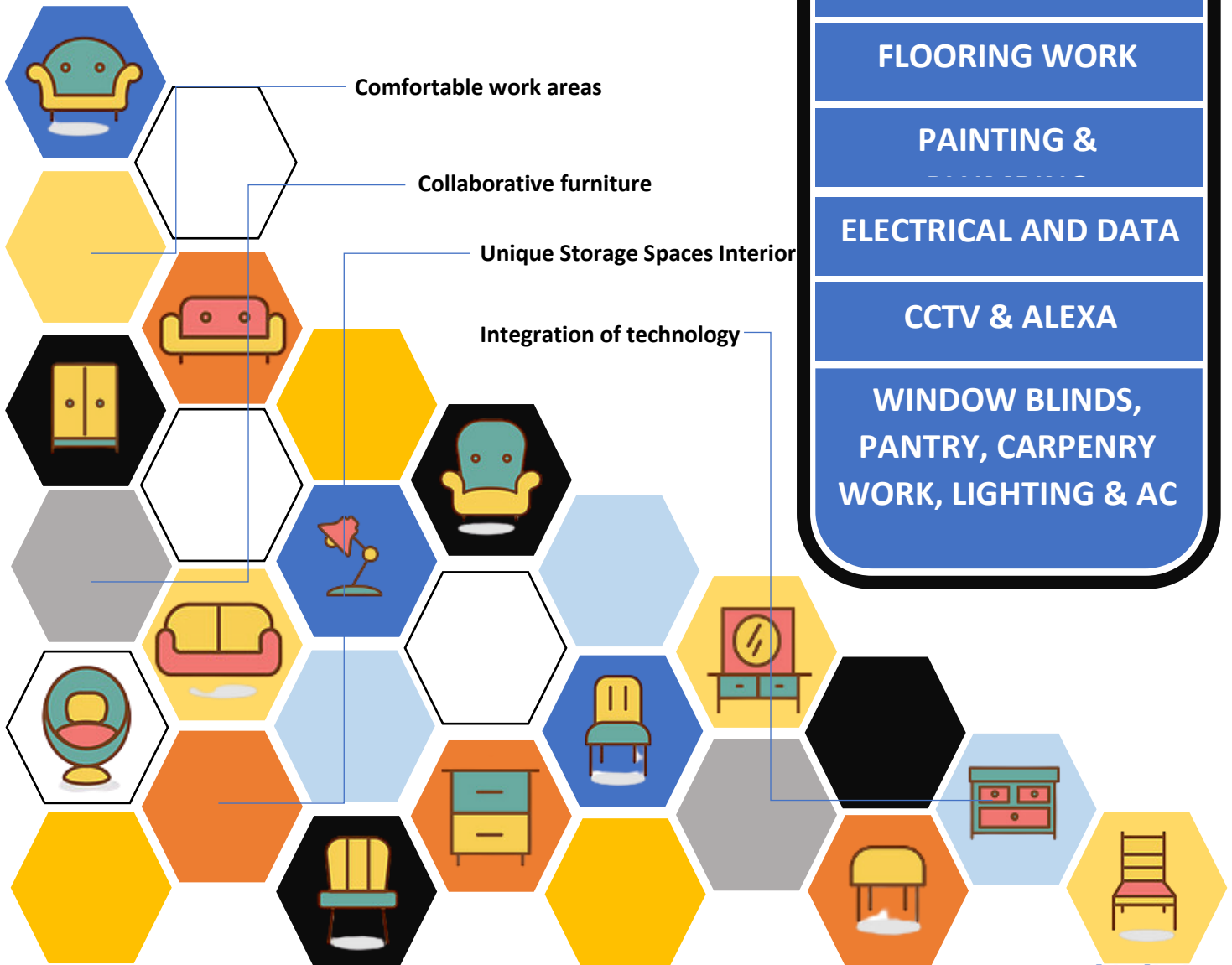

Office

Storage





Solutions **your** One Stop Partner For Storage

Topnotch offer Mobile compactor Storage Systems are designed in high quality. These high storage capacity racks are available in two types: Manual (Hand Push type), Mechanically operated (chain driven) system.

The choice depends on the requirements and space available at customer premises. Our rail mounted racks are suitable for all kinds of storage requirements. Being a quality-oriented firm, we provide best quality products with sales after service. With our vast experience in this field, we are expert solution provider in all kind of storage products. For more info log in to

www.topnotchindia.in



TOPNOTCH MOBILE COMPACTOR LAYOUT

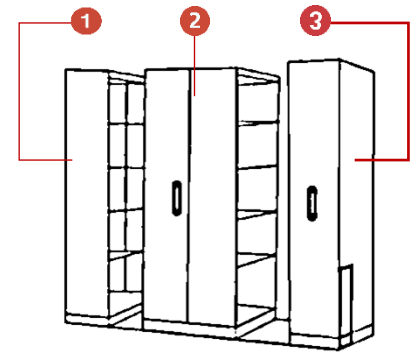
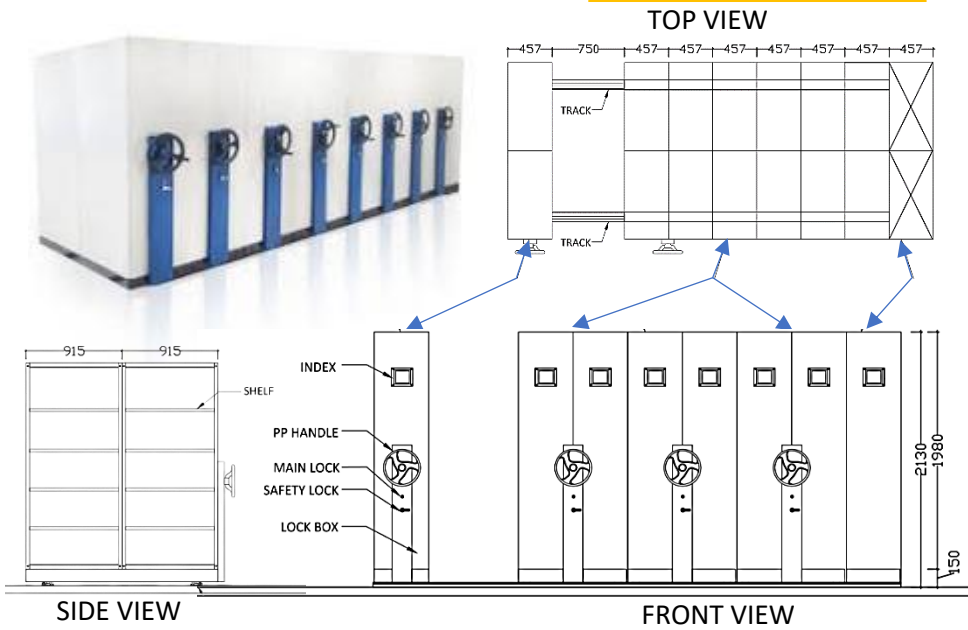

- 1 SINGLE FACED FIXED UNIT**
Size: 2130x915x457mm
- 2 DOUBLE FACED MOBILE UNIT**
Size: 2130x915x915mm
- 3 SINGLE FACED MOBILE UNIT**
Size: 2130x915x457mm

Std Hand Push Specifications:

Types	Models	Height	Width	Depth	Shelves
1 Bay	4 Bodies	2130mm	915mm	457mm	4 Nos with 5 compartments
2 Bay	8 Bodies	2130mm	1830mm	457mm	

Std Mechanical Specifications:

Types	Models	Height	Width	Depth	Shelves
1 Bay	4 Bodies	2130mm	915mm	457mm	4 Nos with 5 compartments
2 Bay	8 Bodies	2130mm	1830mm	457mm	
3 Bay	12 Bodies	2130mm	2745mm	457mm	
4 Bay	16 Bodies	2130mm	3660mm	457mm	

*Customized configurations are available on Request

Space Measurement Index :

Model	No of Body	Space Required	Height Space
TNC 1BAY-4M	With 4 bodies	8 Ft x 3 Ft = 24 sq ft	Min 7 to 8 ft
TNC 1BAY-6M	With 6 bodies	11 Ft x 3 Ft = 33 sq ft	Min 7 to 8 ft
TNC 1BAY-8M	With 8 bodies	14 Ft x 3 Ft = 42 sq ft	Min 7 to 8 ft
TNC 2BAY-8M	With 8 bodies	8 Ft x 6 Ft = 48 sq ft	Min 7 to 8 ft
TNC 2BAY-12M	With 12 bodies	11 Ft x 6 Ft = 66 sq ft	Min 7 to 8 ft
TNC 2BAY-16M	With 16 bodies	14 Ft x 6 Ft = 84 sq ft	Min 7 to 8 ft

*As per the area and your need and for that we have to visit your organization/Office/Space and take measurement and suggest the appropriate model.

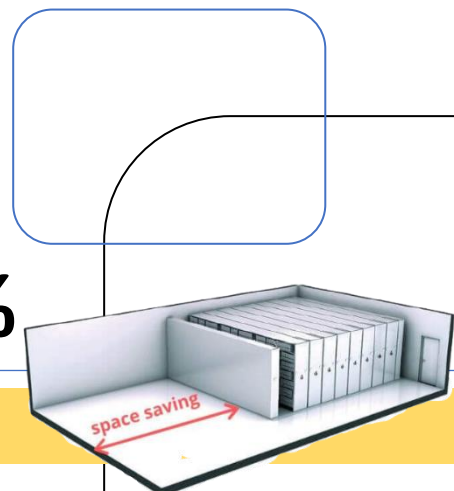
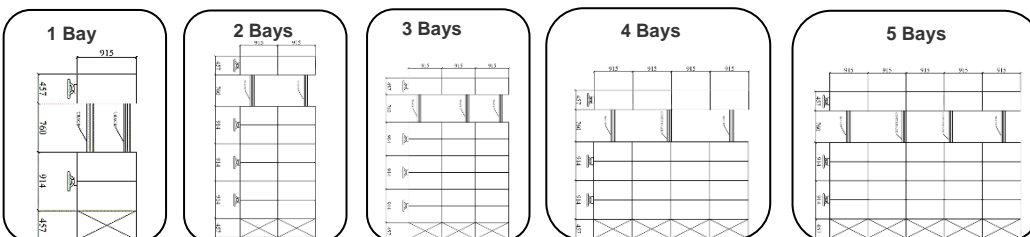

SAVE OVER 50% OF SPACE



Manual Mobile Storage System

- Easy movement mechanism
- Heavy duty tracks
- Ergonomically designed handles to ensure that sliding bays can be moved effortlessly
- Central Locking
- Pre-coated/Powder Epoxy Coating
- Sound Buffer Button
- Shelf Adjustable every 40mm Height
- Easy Retrieval & Reference

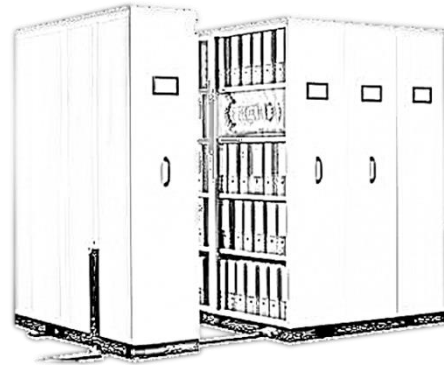

Mechanical Mobile Storage System

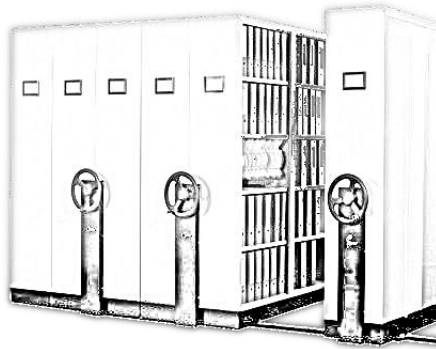

- Anti-tilt
- Central Locking
- Safety Lock
- Sound Buffer Button
- Pre-coated /Powder Epoxy Coating
- Adjustable Shelf
- Easy Retrieval & Reference
- Anti-topple system for stability & safety

Our Mobile Storage System Models



Full cover Compactor

Mechanical Compactor

Hand Push Compactor

Lateral-racks

Central Locking - Safety Lock - Sound Buffer Button - Pre-coated / Powder Epoxy Coating - Adjustable Shelf - Space Saver

Customized Design – free 2 years AMC on Big Requirements - Heavy duty & durable tracks - Cost Effective

--- Dedicated service team available 24x7* ---



We Manage your floor Space, with your loved things



Space is Limited, not Requirement

2023

WHAT. WHEN. HOW.

Application Areas:

- Banks, Hospital
- Govt. Offices
- Pharmaceutical
- Factories, Defence
- Material Organisations
- Public & Private Sectors
- Railways
- Automobile Industries
- Builders, Jewellers

Accessories:

- Step Ladder
- Individual doors
- Pull out drawers
- Sensor Light fittings
- Motorised Customization
- Aisle indicator LED

Benefits:

- Better use of Space
- Safe and secure arrangement
- Effortless Movement
- Easy Assembly
- Single key locking
- Easy identification by indexing



Metal Filling Cabinets

Categorise and store files and folders
To hold large amounts of files without taking up too much floor space
Centre Locking Systems For better Security and easy to handle.
Telescopic Channels for Extra Smoothness and For more strength
Metal Filling Cabinets Comes in 3 Models
4 Drawers Filling Cabinets
3 Drawers Filling Cabinets
2 Drawers Filling Cabinets

Mobile Pedestal

3 Drawers, Centre Locking
Wooden Structured

Mobile Pedestal

3 Drawers, Centre Locking,
Steel Structured



3 Drawers, Centre Locking

Steel Structured

2 Drawers, Centre Locking

Wooden Structured





Steel Almirahs (Big)

L: 900 x W: 475 x H: 1950 mm

With 4 adjustable shelves

Made up of CRCA Sheet



Steel Almirahs (Small)

L: 750 x W: 425 x H: 1500 mm

With 4 adjustable shelves

Made up of CRCA Sheet



Steel Glass Door Almirahs

L: 900 x W: 475 x H: 1950 mm

Stainless Steel key with 6-lever

brass lock. Glass Door,

Made up of CRCA Sheet



L: 825 x W: 300 x H: 1650 mm

Four glass door compartments.

Made up of CRCA Sheet

Door is locked by single key.

LOCKERS CABINET

Steel 4 Doors BookCase

TOP NOTCH
Your Dreams ... Your Furnitures



4 Lockers



6 Lockers (Half)



6 Lockers (Full)



8 Lockers



10 Lockers



12 Lockers



18 Lockers



Z Shaped Lockers





Rational - 01



Rational - 02



Rational - 03



Rational - 04



Rational - 05



Rational - 06



Rational - 07



Rational - 08



Rational - 09



Rational - 10



Rational - 11



Rational - 12

CAFETERIA TABLES



CAFÉ T 01



CAFÉ T 02



CAFÉ T 03



CAFÉ T 04



CAFÉ T 05



CAFÉ T 06



CAFÉ T 07



CAFÉ T 08



CAFÉ T 09



CAFÉ T 10



CAFÉ T 11

CAFETERIA CHAIR



CAFÉ C 01



CAFÉ C 02



CAFÉ C 03



CAFÉ C 04



CAFÉ C 05



Your Wealth Safety is our First **Responsibility**



Strong Room Door



Safe Deposit Lockers

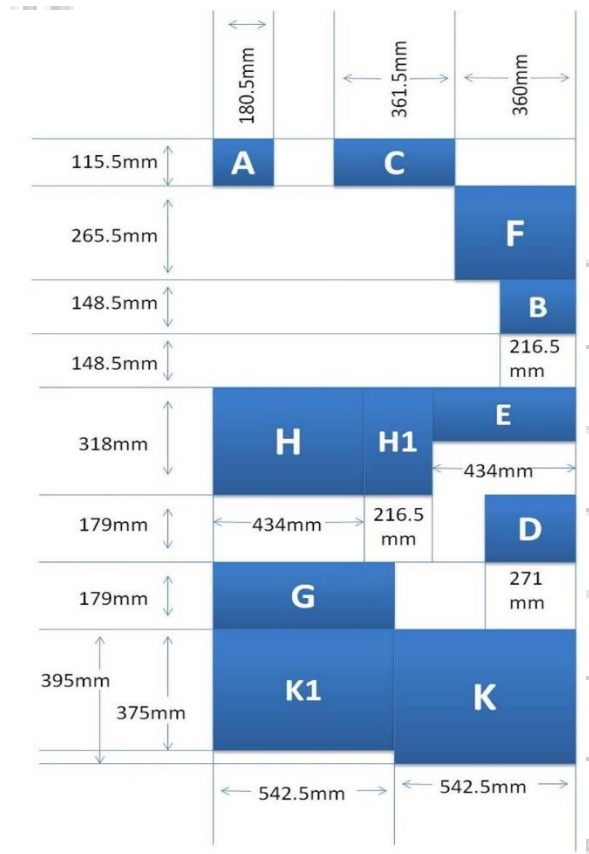

SAFE DEPOSIT LOCKERS

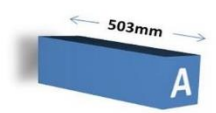

INTERNAL DIMENSIONS
WIDTH SIZE (FOR ALL SIZE LOCKERS)

SECURITY SOLUTION

LOCKERS & SAFE



Cash Box

Locker Cabinet

Fire Protection Cabinet

Fire Resisting Filling Cabinet

Burglary Safe

HOSPITAL PRODUCT



(HF 155)

(HF 91 153)

(HF 101) ICU BED MECHANICAL

CORNER TABLE



| CORN-01

| CORN-02

| CORN-03

| CORN-04

| CORN-03

A wonderful seating system designed to provide the perfect solution to small and large breakout and reception areas. The option of back with side screens provides even more privacy making these a very versatile range with tubular steel legs & sateen silver finish



Relax

Meet

Discussion Desk

Privacy

Modular Kitchen

By topnotch

DESIGN

MAKING

INSTALL



TOP NOTCH

Your Dreams ... Your Furnitures

1. **Design Options** – Topnotch Modular kitchens are available in a wide range of materials, finished, textures etc. The options are practically unlimited and the wide range of options means that the relative cost of the modular kitchen has come down over the years.
2. **Manufacturing** – We (Topnotch) are one of fastest Growing Modular Kitchen manufacturing in Jaipur Rajasthan. We have expert teams to help you from Design to its execution.
3. **Installation** – It allows for a hassle free and quick move in since the installation of the entire kitchen takes only 3-4 days depending on the size.

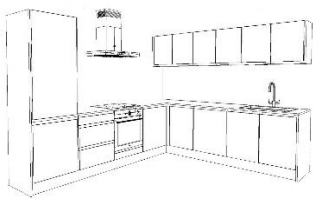

| L-Shaped

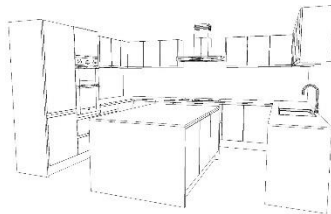

| U-Shaped

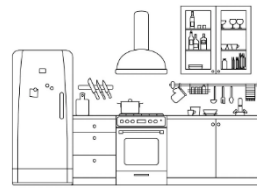

| Single Wall

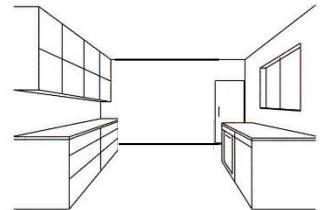

| Parallel Shaped

We Understand Your Kitchen By 5 Areas

Working Principal that Gives Better Option



| Consumable



| Non-Consumable



| Cleaning Area



| Preparation Area



| Cooking Area



STEEL MODULAR KITCHEN

BEST IN THE SEGMENT

Body of the Cabinets Pre-Coated Steel Sheet - Resistant to Corrosion & Extreme Temperature Conditions

Carcases & Shutters - Noise-Free Double Sheet Sandwich Technology makes Entire Kitchen Noise Free.

Kitchen Design System Each Cabinet is an Independent Module unit. Advantages : Units can be retrieved / changed independent of the adjoining units. Units can be dismantled/ moved at any point of time.



- Fully Customised, Planned And Built To Satisfy All Your Functional Requirements
- Completely Noise-Free Metal Kitchens Termite-Proof, Rust Resistant, Durable & Long-Lasting, Strength Of Steel
- Pre-Coated Sheet Carcasses, Gi Sheet 100% Powder Coated Shutters,
- Hettich Hinges & Channels.
- Superbly Aesthetic & Cost Efficient
- Packed And Delivered Right At Your Doorstep, Readily Installable.
- Warranty On Entire Kitchen System
- Service Support Directly From The Company, Assured Prompt After-Sales Service By Company's Technicians.
- Pest- Proof Completely Sealed Kitchen With No Holes.



OUR OTHER CREATIVE SOLUTIONS

We can help you design your perfect office. and create your perfect space. We measure your space, identify your requirements to design and create an ideal plan to suit your needs



DESKING SOLUTIONS

OFFICE TABLE – COMPUTER TABLE – WORKSTATION – CONFERENCE TABLE



SEATING SOLUTIONS

OFFICE CHAIR – HOME CHAIR - SOFA



STORAGE SOLUTIONS

ALMIRAH – LOCKERS – SAFE – RACKS – WARDROBE



SECURITY SOLUTIONS

CASH SAFE – LOCKERS – FRFC -FRRC -STRONG ROOM DOOR - CCTV



INTERIORS SOLUTIONS

ONE STOP SOLUTION FROM DESIGN TO IT'S EXECUTION



MODULAR FURNITURE

MODULAR KITCHEN – WARDROBES – BEDS -

Send us Your Requirement for Customize Furniture





Topnotch is more than a business
Strong. Spacious. Durable.

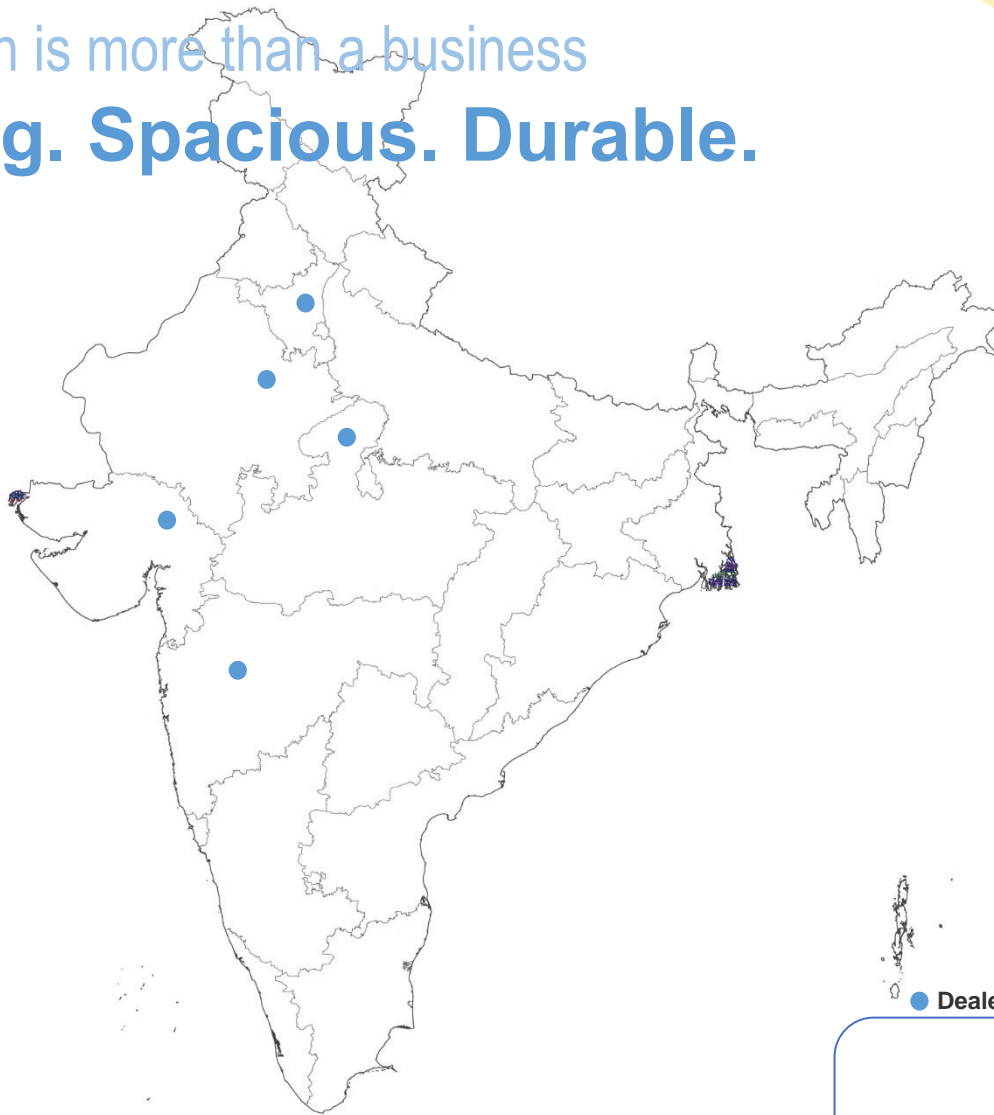

● Dealer Name & Address :

Topnotch Corporation

Mo: +91-9587820603, 7014389936 | Ph: +91-141-3136956

Regd. Add: 38, Ganeshnagar 5th, Macheda, VKIA Area, Jaipur (Raj.) 302013, India

Follow us on Social Media !!  | E-mail: info@topnotchindia.in | Web : www.topnotchindia.in

